

TPH-2 TRADE PRO

Operation & User Manual

IMPORTANT - PLEASE NOTE

Read this instruction set fully before fitting or using TPH-2 tools.

- TPH-2 Trade Pro tools are reliant upon the installers and users ability to determine that vehicle registration plates are securely and appropriately affixed to vehicles.
- Information notes and tips included in these instructions will make your user experience easy

PLEASE SEE PAGE 2 FOR FURTHER UNLOCKING AND FITTING TIPS

Your TPH-2 boxed kit comprises:

2x TPH-2 Fixture Tool assemblies

2x 'Universal Number Plate Adaptor'

• Plates pre-installed into TPH-2 tool storage and transport position

2x 'Recessed number plate tool'

1x Instruction set

Plastics - 'development proven' materials are tough to withstand inconsiderate user handling

White Arrow – Indicates a design feature enabling user induced variation of the 'Tang' jaw width as is required to engage and disengage TPH-2 to vehicle number plates (and to remove and lock in the 'adaptor' plate).

Usage instruction set definition

- A 'Standard' United Kingdom registration plate height measures 110.5 to 112mm high.
- A 'non standard' plate height exceeds 112mm

Standard 111mm UK vehicle registration plate fitting instructions

To affix a Trade Plate to a 'standard' 111mm UK vehicle registration plate please refer to page 2.

Affixing the Trade Plate to number plates exceeding 112mm high

To affix a Trade Plate to number plates taller than the UK 'standard 111mm plate' refer to instructions starting page 4

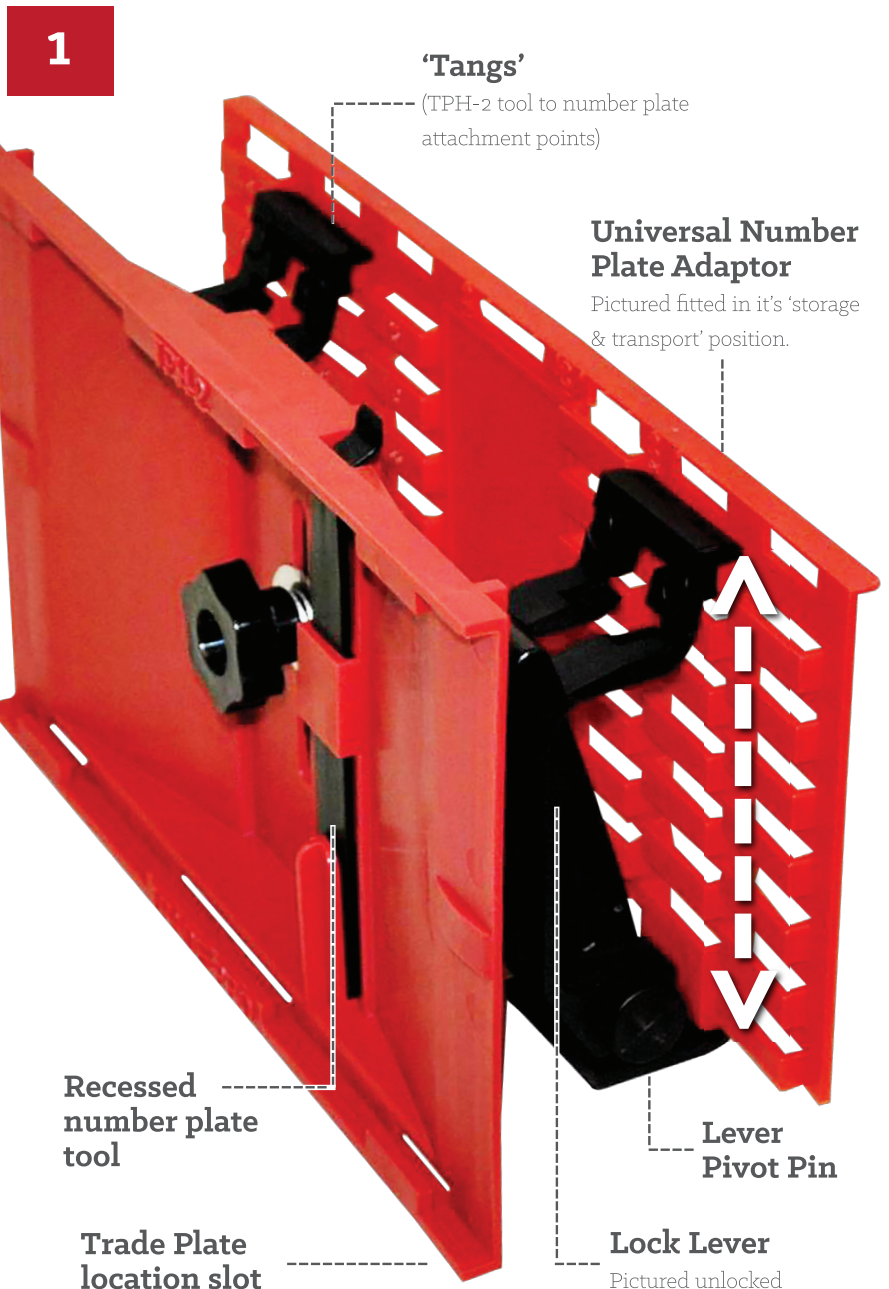

TPH -2 Unlocking and fitting tips

Manufacturer	Models	Front	Rear	Advice
All	TPH-2 Unlocking tips	✓	✓	<p>TIP – Load the T handle unlock lever to induce a twist which makes unlocking easier</p> <p>TIP – Occasionally grease the seats of both T handle 'barrel seats' – see instruction set - photo 5B</p>
All	Rear number plate fits		✓	<p>TIP – In approximately 50% of instances the fixture is easier to fit when rotated 180 degrees, therefore with the lock lever T handles will be oriented to the underside.</p>
Audi	<p>Audi front - TPH-2 fits if the number plates are screw affixed.</p> <p>May fit when tape affixed, if the tape is not absolutely edge aligned.</p>	✓✗	✓	<p>TIP – Current Audi's have a front bumper feature in which number plate is recessed and flush aligned to the upper edge. If the number plate is screw affixed then TPH-2 will fit using the recessed number plate tool to 'tease out' and expose the number plate top edge.</p> <p>TIP – TPH-2 generally affixes to most Audi rear number plates when rotated 180 degrees</p> <p>CAUTION – If the front number plate is adhesive tape affixed then TPH-2 installation may be impossible</p> <p>CAUTION – TPH-2 is incompatible with Audi Q7's 'wavy' grille feature</p>
Ford	Mondeo Hatchback	✓	✓	<p>TIP – TPH-2 affixes to rear when rotated 180 degrees</p>
Mercedes	All recent models	✓	✓	<p>TIP – Applies only when number plates are installed into a 125mm high Mercedes supplied number plate frame</p> <p>TIP – The lock lever handles must be oriented underside and the 'non standard number plate height adaptor' plate must be utilised with TPH-2 tangs engaged into the 125mm adaptor plate slot and the adaptor plate edge engaging to the underside of the number plate frame</p> <p>TIP – The TPH-2 lower tang is wider than the top tang facilitating Mercedes number plate frame fitting</p>
Würth Klapp-Fix number plate holder		✗	✗	<p>CAUTION – TPH-2 is incompatible with Würth 'Klapp-Fix' number plate frame article # 0825 990</p>

Check out our 'tip' videos especially regarding unlocking – links from our website www.btrprep.co.uk

Our trade plate holders are different to traditional fixtures and feature familiarity is useful and the 'tip and tutorial' videos aim to quickly inform and pass on 'user experience'

INFO - MAIN BRACKET FLEX POTENTIAL

Right - 110 and 120mm ruler sections inserted between both tang pairs demonstrates user induced flex potential. The dimension between the top and bottom tangs can be increased by user induced flex when a lever is 'Unlocked' (as per image 4 over the page)

The dimension between the top and bottom tangs is tightly controlled when a lever is 'Locked' (as per image 5 over the page)

2



Standard 111mm UK vehicle registration plate fitting instructions

1. Orient the TPH-2 tool with the lever 'T' handles directly above the lever pivot pins, as image 4.
2. Set both main frame levers to the unlocked position - as image 4.
3. Release the 'Universal Adaptor Plate' (adaptor) from its 'store' position - hold and expand a top/bottom tang pair apart as per the white arrow on image 1.
4. Put aside the adaptor plate (which is only required to attach TPH-2 tools to 'non standard' registration plates).
5. Engage the upper pair of TPH-2 tangs onto the top edge of the number plate (images 5 & 6)

3



Adaptor Plate

Not needed for standard registration plates

4

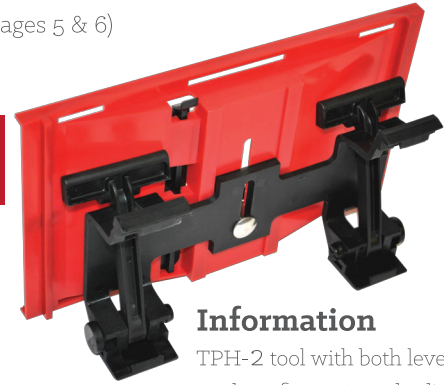

Information

TPH-2 tool with both levers unlocked ready to fit to a 'standard' number plate.

5A



Lubricate barrel seat



Tang engaged correctly, the tang point is fully engaged behind the number plate edge.

5B



Lubricate barrel tracks



INCORRECT – The tang point is on (and not behind) the number plate top edge

Lubrication tip – occasionally lubricating the lever 'barrel track' helps smooth lever releases - image 6 refers

6. With the levers unlocked, and the lower tang pair touching the number plate face, gently press the lever 'T' bar top pressing downward directly toward the lever pivot pin. Your finger pressure will stretch the bottom tangs down and after about 5mm of downward movement a click will be felt (and heard) as the bottom tang slips off the number plate face engaging with the number plate bottom edge. **The tang points may be on but not yet engaged behind the number plate at this stage.**
7. Move the 'T' lever handles into the 'locked' position (T handle nearest to the vehicle registration plate)

INFO

The TPH-2 tang 'points' have a 'leading edge' feature and the majority of number plates have chamfered edges therefore as each TPH-2 lever is locked the top and bottom tangs are pushed into the gap between the body panel and the number plate. The body to number plate gap may be near invisible however the tang will slightly 'lift' the number plate edges off the panel as it 'finds' its way into the gap.

TIP - practice and familiarisation with procedure 7 speeds fitting times

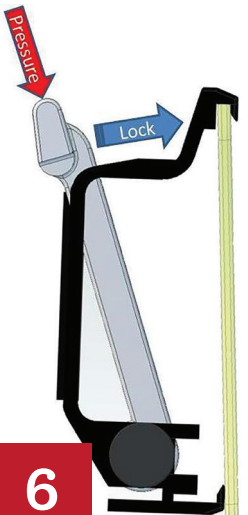

6

8. Visually check that all four tangs are correctly engaged behind and onto and behind the number plate rear face as per image 5A. If a tang is not correctly located, (image 5B being an example) then release the locking lever, adjust the tang position and repeat the lock procedure until correct. The recessed plate tool can be useful to 'lift' number plate edges lacking a radiused rear edge.
9. Adjust the Trade Plate facia height and insert your Trade Plate into the facia slots (see Page 7 notes regarding checking and adjusting Trade Plate facia retention load)
10. Twist and pull the Trade Plate/TPH-2 tool/number plate assembly until satisfied that your Trade Plate is securely attached to the vehicle

Suggested safety measure

Have a third party familiar with TPH-2 and TPH-D tools double check your installation before driving on a public highway (as a minimum measure implement as a risk management procedure until installer/users become familiar with TPH-2 tool fitting)

The image on the right shows a TPH-2 main frame installed and 'locked' on to a UK 'standard' vehicle registration plate.

Note that the registration plate pictured in image 7 is mounted within a chrome trim frame therefore the plate edges are 'normally' recessed.

The 'recessed number plate tool' has been used to tease out and expose the number plate edges to enable tang engagement.

Note that the Trade Plate fascia plate has been removed for instructional purposes in image 7. The fascia plate need not be removed normally, although when plates are recessed it can make tang and thus main frame fitting easier.

Lever 'unlock' Tip

Development experience suggests the easiest method to unlock levers is to position a thumb to the main bracket as indicated in image 7 while applying the unlock force to the 'T' lever edge with the forefinger side. Lever 'twist' induced by this method assists releasing the lever.

Lever 'unlocking'

Recommended thumb pressure point



Levers set to locked position

Image 7 shows both levers currently set to the locked position

Fitting the TPH-2 Trade Pro to number plates exceeding 112mm high

Step One

Using the measure scale imprinted to the TPH-D adaptor plate top edge accurately determine the number plate height.

(Scale text = 120, 160 & 200mm with 10mm interval points)
The example number plate in image 8 measures 150mm.



Step Two

Engage TPH-2 tool upper tangs (nearest the lever handles) into the appropriate adaptor plate slots.

The example in image 9 requires the upper tangs engaging into the 150mm slots

Step Three

With the locking levers 'unlocked' engage the TPH-2 adaptor to the vehicle number plate top edge

Step Four

Follow the previous instructions from and including page 2, instruction 6. (the rest of the fitting procedure and checks are as per fitting TPH-2 tools to 'standard' height number plates)



Trade Plate offset to body feature adjustment

Height Adjust Knob

The face of the height adjust knob is positioned intentionally to load the back of your Trade Plate, thus creating 'sticktion' to prevent unintentional removal of the Trade Plate.

To adjust Trade Plate 'sticktion' between your Trade Plate and the Trade Plate facia add washer(s) between the facia height adjust knob and the Bellville preload washer to be found at joint [X]

Safety Notices

TPH-2 Tools are designed to display 'new style' Perspex Trade Plates. Old style Aluminium Trade Plates must have extra washers added (into the joint marked X on photo 14) to achieve an appropriate 'sticktion' value to retain the Trade Plate in the facia moulding.

Failure to adjust your TPH-2 tools to accommodate old style Trade Plates may result in the loss of your Trade Plate! Aluminium Trade Plate 'tax triangle' features are incompatible with TPH-2 tools and must be removed.

Trade Plate facia offset adjust knob & slot.

Range = 100mm / 4"

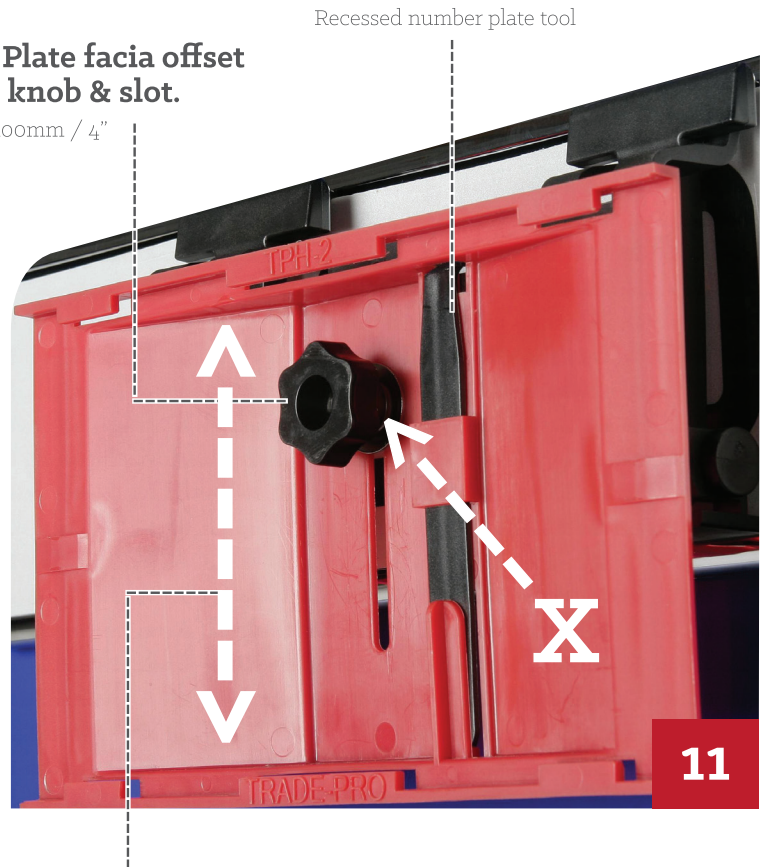

TP offset adjustment range = 100mm

Trade Plate 'recessed number plate' tool

A 'recessed number plate tool' is fitted into the Trade Plate facia to assist to 'lift' recessed number plate edges out of number plate frames to expose edges and enable TPH-2 installation. The tool is supplied as a user aid without any inference that TPH-2 tools will attach to recessed number plates.

Image 12 examples a TPH-2 fixture fitted to a 'standard' number plate viewing from the rear toward the front face. The 'dummy number plate' is yellow to highlight the tang fitted positions.

Note that both left tangs and the right lower tang are correctly located while the right upper tang is incorrectly sat on the 'number plate' edge. In this instance tang position adjustments are required before the lever is set into the 'locked' position.

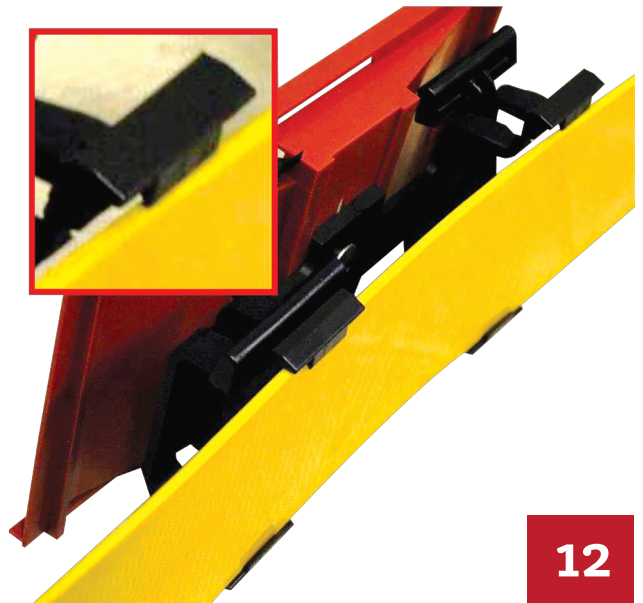

Facia plate adjust nut tensioning washer orientation



Disclaimer

TPH-2 TRADE PLATE FIXTURE TOOL ATTACHMENT RELIABILITY IS ABSOLUTELY RELIANT UPON THE COMPETENCE AND ABILITY OF USER/INSTALLERS TO ASSESS AND ENSURE THAT VEHICLE NUMBER/REGISTRATION PLATES ARE SUITABLY AND SECURELY AFFIXED AND THUS APPROPRIATE MEDIUMS BY WHICH A TPH-2 FIXTURE TOOL AND 'TRADE PLATE' CAN BE RELIABLY AFFIXED

A TECHNICALLY PROFICIENT THIRD PARTY MUST ENSURE THAT ALL FIXTURE TANGS ARE CORRECTLY ENGAGED AND THE LOCKING LEVERS FULLY 'LOCKED' BEFORE USERS DRIVE ON PUBLIC HIGHWAYS

A TECHNICALLY PROFICIENT THIRD PARTY MUST ENSURE THAT TRADE PLATES ARE SECURELY AFFIXED INTO THE TPH-2 FACIA PLATE BEFORE USERS DRIVE ON PUBLIC HIGHWAYS

DURING PUBLIC HIGHWAY TRANSPORTATION PERIODS TPH-2 TRADE PLATE FIXTURE TOOLS USERS MUST UNDERTAKE REGULAR REGISTRATION, TRADE PLATE AND TPH-2 TOOL SECURITY CHECKS.

Risk assessment advice

What are the hazards?	Who might be harmed and how?	What are you already doing?	Do you need to do anything else to control this risk?
Vehicle number plate to vehicle body attachment failure	Persons & property		
TPH-2 Trade Plate Fixture tool to vehicle number plate attachment failure	Injury or damage due to impacts as an assembly or as impact separated components.	<p>'Trade Plate' installation training to familiarise installer/users with TPH-2 fixture tool fitting instructions, recommendations, limitations and potential risks.</p> <p>Practical tests to quality control user/installers ability to assess number plate fixations and suitability as TPH-2 attachment mediums.</p> <p>Third Party installation check policy implementation</p>	

LATEST VERSION: For the latest version instructions, technical updates, training and demonstration tutorials and more refer to www.btrprep.com or our YouTube channel 'TPH-2 Trade Pro - Trade Plate Fixture Tool'.

Credits

Design advice and testing:

Images:

Land Rover images

Philip Welch Specialist Cars

Bob Walker Photography

Guy Salmon Land Rover, Wakefield

www.philipwelch.co.uk

www.bob-walker.co.uk

www.guysalmon.wakefield.landrover.co.uk